

# **Instructions for Use of 8-channel Isolated Analog Data Acquisition Module**

## ■ 1 Product Description

### 1.1 Introduction

This is an 8-channel single-end 12-bit analog data acquisition module with an accuracy of up to  $\pm 1\%$ , supporting 0-5V, 1-5V, 0-2.5V, 0-20mA, 4-20mA ranges. It can collect multiple channels simultaneously, and can also collect voltage and current at the same time. The module RS485 communication interface has optoelectronic isolation, and the application layer adopts the standard Modbus RTU protocol, which conforms to industrial standards. It can be conveniently used to communicate with the host computer. You can use this module to realize rapid networking, build a monitoring system, or connect with PLC, configuration software, Industrial Personal Computer, OPC, and other systems.



Each channel of the module is independent, which can set the range independently. There are a variety of ranges to choose from, and users can switch them at will according to their needs. In addition to supporting standard 4-wire sensors, it also supports 2-wire and 3-wire sensor inputs.

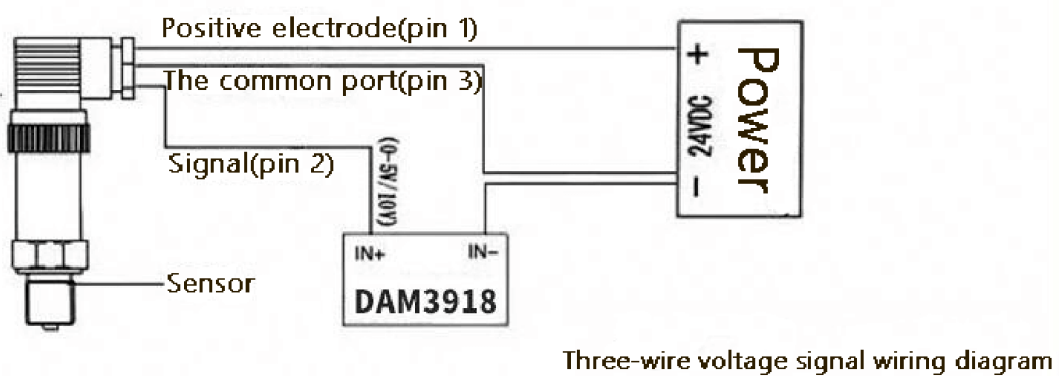
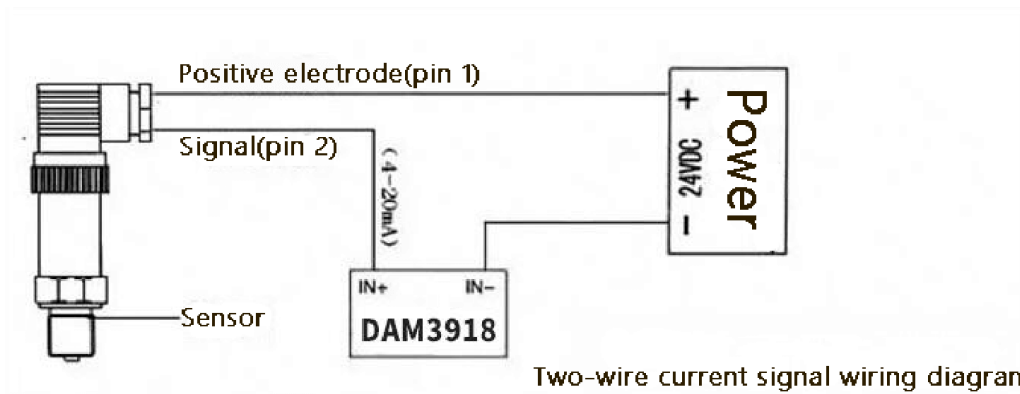

Security is extremely guaranteed. The product has communication isolation and input/output isolation, so that it can not only resist interference during use, ensure accurate and stable data transmission, but also in case of strong electricity, it will only burn out the collection product at most and the entire system will not be damaged. The module supports a 12-30V wide voltage power supply, and the interface adopts an anti-reverse design.

## 1.2 Product Dimension Chart (unit: mm)

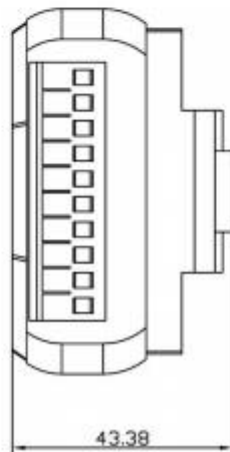
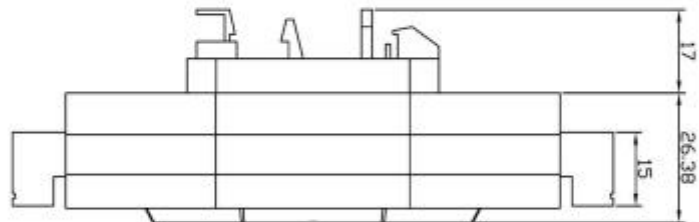
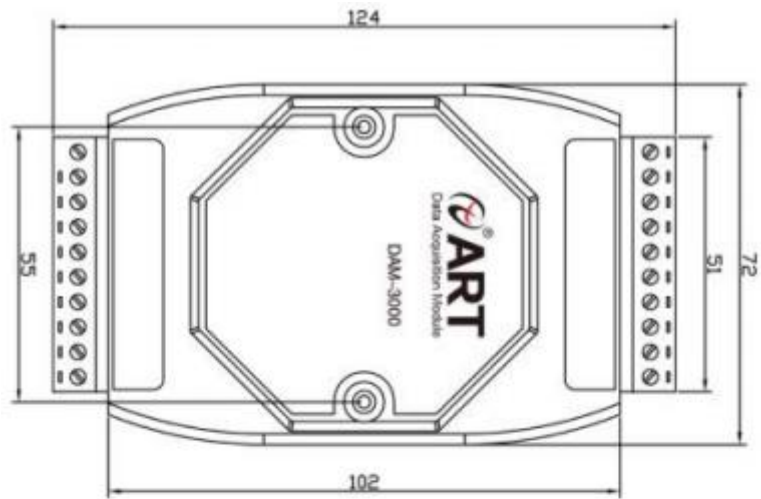

### 1.3 Main Parameters

8-channel single-port analog acquisition module

<b>Analog input</b>	
Input channel	8 single-port analog inputs
Input type	Voltage input, current input
Acquisition range	0~5V, 1~5V, 0~2.5V, 0~20mA, 4~20mA Default factory value 4~20mA

Sampling rate	400sps (total channels) 50sps (single channel)
Resolution	12 bits
Acquisition accuracy	1‰
Input resistance	Voltage range: 10MΩ Current range: 249Ω
Range setting	The range of each channel can be independently configured
<b>Others</b>	
Communication Interface	RS485
Isolation voltage	1500VDC
RS485 transmission rate	Maximum 180 times/sec (total channel of a single module, in the case of 115200bps) Maximum 24 times/sec (total channel of a single module, in the case of 9600bps) Maximum 3 times/sec (total channel of a single module, in the case of 1200bps)
Baud rate	1200~115200bps
Watchdog	Software watchdog
Supply voltage	+18~30VDC
Power protection	Power reverse protection
Power consumption	Rated value 0.5W @ 24VDC
Operating temperature	-40°C ~ +80°C
Storage temperature	-40°C ~ +85°C

**Note:**

- 1. Sampling rate:** This parameter refers to the acquisition speed of the ADC chip.
- 2. Data communication rate:** This parameter refers to the communication speed between the MCU controller and the host computer.

## 1.4 Module Instructions

### 1. Pinout Table

Port	Name	Description
1	IN5+	Analog input 5 channel positive
2	IN5-	Analog input 5 channel

		negative
3	IN6+	Analog input 6 channel positive
4	IN6-	Analog input 6-channel negative
5	IN7+	Analog input 7 channel positive
6	IN7-	Analog input 7-channel negative
7	DATA+	RS-485 interface signal positive
8	DATA-	RS-485 interface signal negative
9	VS+	DC power input positive
10	GND	DC power input ground
11	IN0+	Analog input 0 channel positive
12	IN0-	Analog input 0 channel negative
13	IN1+	Analog input 1 channel positive
14	IN1-	Analog input 1 channel negative
15	IN2+	Analog input 2 channel positive
16	IN2-	Analog input 2 channel negative
17	IN3+	Analog input 3 channel positive
18	IN3-	Analog input 3 channel negative
19	IN4+	Analog input 4 channel positive
20	IN4-	Analog input 4 channel negative

**Note: The negative terminals of analog input 0~7 channels are connected together internally. All analog negative terminals and GND are connected together.**

## 2. Block diagram of the internal structure of the module

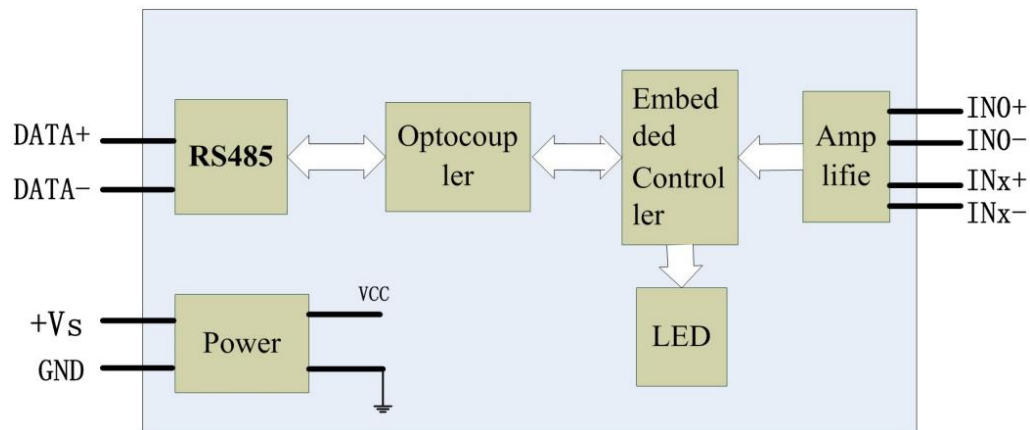

## 3. Internal jumpers and reset button

The jumpers J0~J7 inside the module are used to select channels 0~7 as voltage or current input respectively (see Figure 4 for the corresponding method). When J0~J7 are short-circuited, it is current input (short-circuit resistance is 249Ω), when J0~J7 is disconnected, it is voltage input.

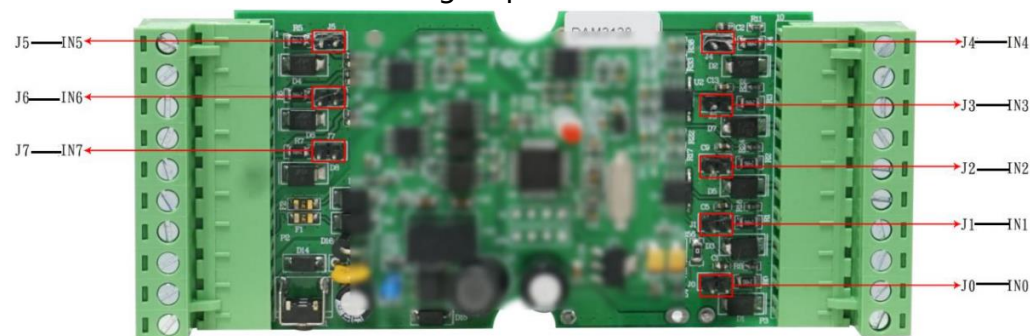

**Note:** The factory default current range of this module is 4~20mA. When the customer selects the voltage range, you need to remove the 2 screws on the front shell, open the shell, and then unplug the jumper caps for J0~J7, and select the voltage range in the upper computer software. For the operation method of the software, please refer to *3. Software instructions*. The upper cover of the shell is easy to be inserted upside down, please refer to the figure below for correct operation:

a. The analog print on the shell film corresponds to the analog print on the board, as shown in the figure:

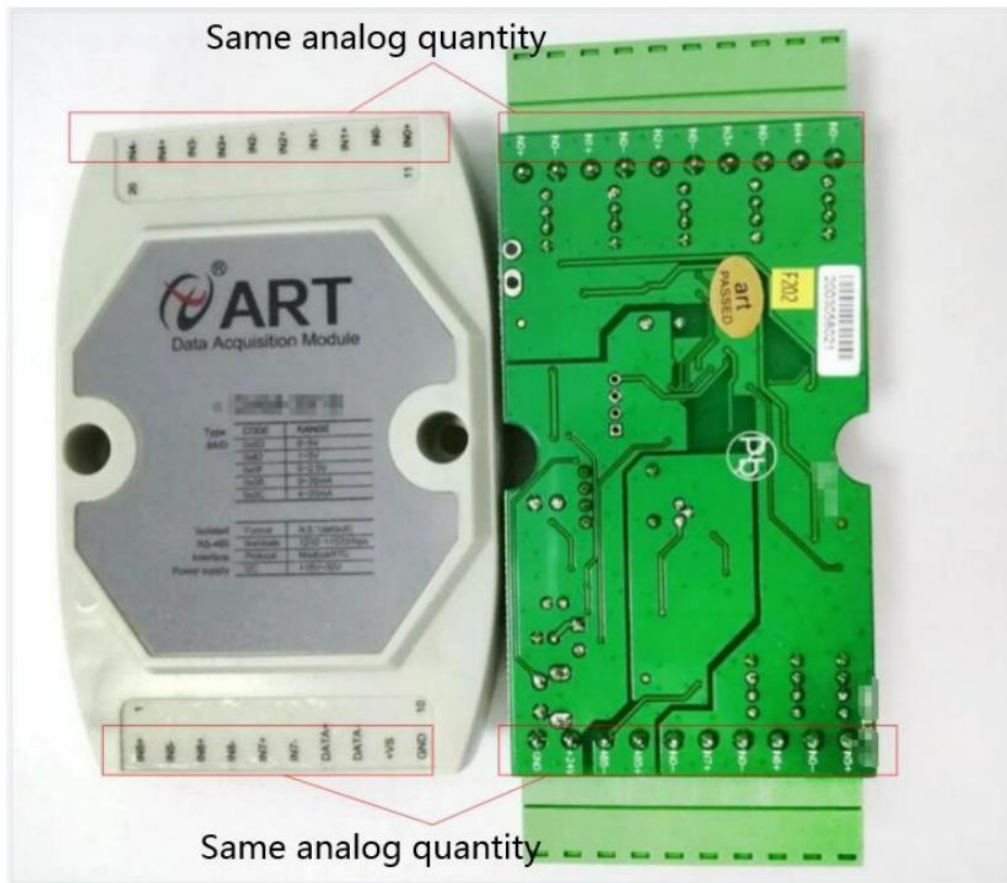

**b. The mounting holes inside the top and bottom cases need to be aligned and fit snugly, as shown in the figure:**



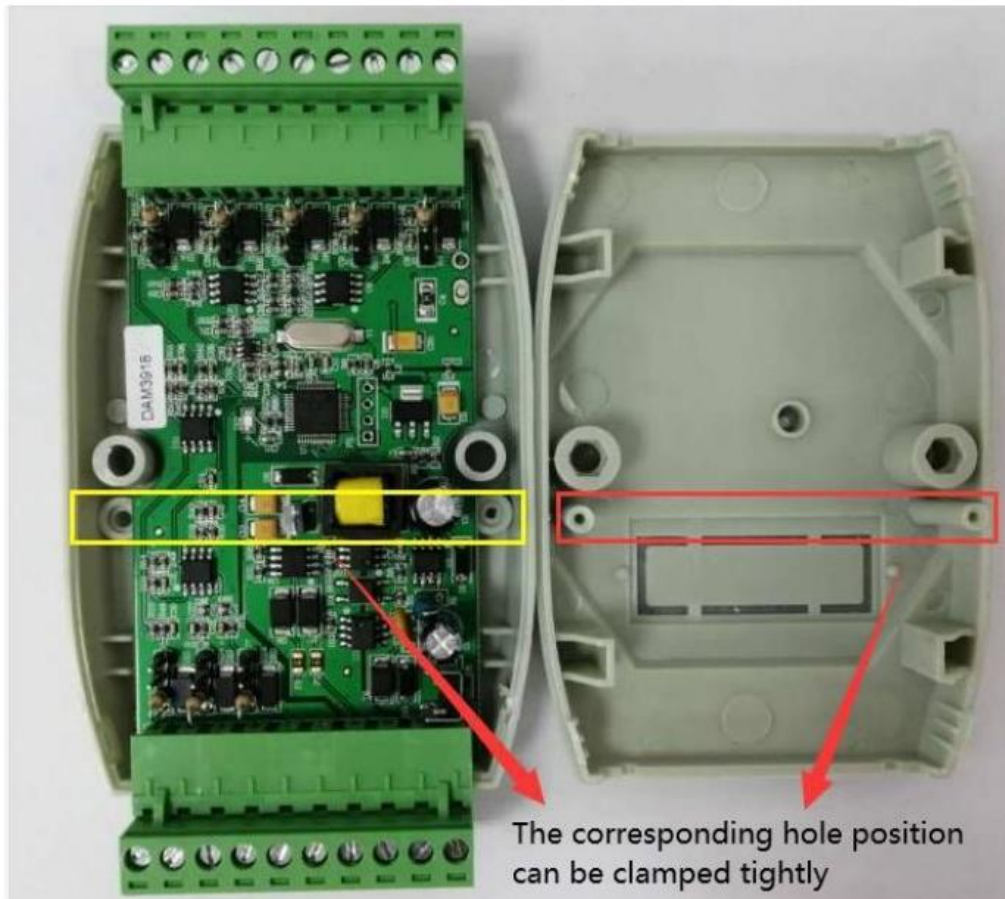

The button S1 inside the module is used to restore the factory mode. Before powering on, press and hold the S1 button, the module indicator flashes 3 times quickly when powered on. When it stops, the module has been reset at this time. Power off and power on again, then the module is restored to factory default settings. The position of the S1 button hole on the shell is shown in the figure below:



#### 4. Power supply and communication line connection

The power input and RS485 communication interface are shown in the figure below. The maximum voltage of the input power is 30V. Exceeding the range may cause permanent damage to the module circuit.

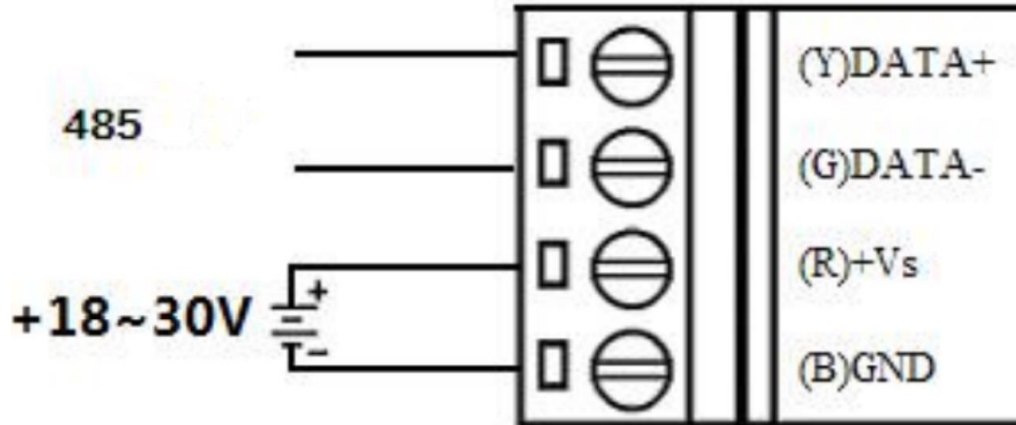

#### 5. Indicator light description

The module has a running indicator. When the power is on and there is no data transmission, the indicator light keeps on; when there is data in transmitting, the indicator light flashes; when the S1 reset button is short-circuited, power on the module, the indicator flashes 3 times quickly.

#### 6. Analog input connection

The module has a total of 8 single-port analog inputs (0~7 channels). There are two input types: voltage and current. The input type needs to be set after connecting to advanced software. The factory default setting is 4-20mA. The maximum input voltage of a single channel is 5.5V. Exceeding this voltage may cause permanent damage to the module circuit.

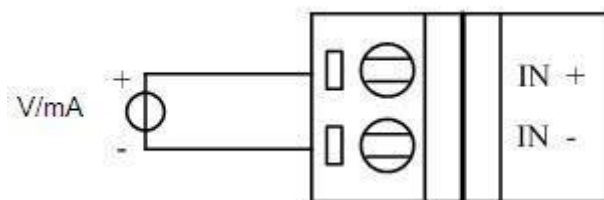

## ■ 2 Configuration Instructions

### 2.1 Code configuration table

#### 1. Baud rate configuration code table

Code	0x0000	0x0001	0x0002	0x0003	0x0004	0x0005	0x0006	0x0007
Baud rate	1200	2400	4800	9600	19200	38400	57600	115200

## 2. Analog input range configuration code table

Input type	Range	Maximum error	Code
V	0 ~ 5V	±0.2% FS	0x000D
V	1 ~ 5V	±0.2% FS	0x0082
V	0 ~ 2.5V	±0.2% FS	0x000F
mA	0 ~ 20mA	±0.2% FS	0x000B
mA	4 ~ 20mA	±0.2% FS	0x000C

## 2.2 MODBUS Address Allocation Table

1. The commands for reading data registers and setting module parameters are shown in the following table:

Address 4X	Description	Attributes	Description
40129	Module type register	Read only	For example: 0x39, 0x18 means DAM3918
40130	Module type suffix register	Read only	For example: 0x42, 0x44 (HEX) means 'BD' (ASCII)
40131	Module MODBUS protocol identifier	Read only	' + ' : 2B20(HEX)-ASCII
40132	Module version number	Read only	For example: 0x06,0x00 means version 6.00
40133	Module address	Read and write	Bit15_Bit 8 must be input as 0. Bit7_Bit 0 Module address, range 1~255. Such as: 01
40134	Module baud rate	Read and write	For example: 0x0003-9600bit/s, other baud rates are shown in the table above
40135	Parity check selection	Read and write	0x0000: No parity; 0x0001: Even parity;

			0x0002: odd parity;
Reserve			
40201	The 0th analog input range	Read and write	Bit15_Bit 8 must be 0. Bit7_Bit 0 Output range. Such as 0x000B: 0~20mA, other ranges are shown in the table below
40202	The 1st analog input range	Read and write	
40203	The 2nd analog input range	Read and write	
40204	The 3rd analog input range	Read and write	
40205	The 4th analog input range	Read and write	
40206	The 5th analog input range	Read and write	
40207	The 6th analog input range	Read and write	
40208	The 7th analog input range	Read and write	
Reserve			
40577	Safe communication time	Read and write	When the module does not communicate with the host during the set time, reset the module to ensure that the communication and module status are controllable. 0~65535, the unit is 0.1S, the default is 0, when set to 0, it is considered that the function is not enabled

Address 3X	Description	Attributes	Description
30001 (or 40001)	The 0th analog	Read only	0~4095

	quantity acquisition value		corresponds to the maximum and minimum values of the range, the corresponding relationship is shown in Table 6
30002 (or 40002)	The 1st analog quantity acquisition value	Read only	
30003 (or 40003)	The 2nd analog quantity acquisition value	Read only	
30004 (or 40004)	The 3rd analog quantity acquisition value	Read only	
30005 (or 40005)	The 4th analog quantity acquisition value	Read only	
30006 (or 40006)	The 5th analog quantity acquisition value	Read only	
30007 (or 40007)	The 6th analog quantity acquisition value	Read only	
30008 (or 40008)	The 7th analog quantity acquisition value	Read only	

**Note:** 03 and 04 function codes can be operated to read AD collected values.

2. Relationship between the value of the data register and the input analog quantity (all linear relations):

Analog input range	Digital number of data register (decimal)
0V ~ 5V	0-4095 (0V=0, 5V=4095)
1V ~ 5V	819-4095 (1V=819, 5V =4095)
0V ~ 2.5V	0-2048 (0V=0, 2.5V =2048)
0 ~ 20mA	0-4095 (0mA =0, 20mA =4095)

4 ~ 20mA	819-4095 (4mA=819, 20mA=4095)
----------	-------------------------------

## 2.3 Modbus communication example

### 1. 04 function code

Used to read the input register, the read is a sixteen-bit integer or unsigned integer.

For example:

The module address is 01, read the sampled value of channel 1~8.

Host send:	<u>01</u>	<u>04</u>	<u>00 00</u>	<u>00 08</u>	CRC
	Device address	Function code	Register address	30001	Number of registers
Device return:	<u>01</u>	<u>04</u>	<u>10</u>	<u>0F FF 0F FF 0F FF 0F FF 0F FF 0F FF 0F FF 0F FF 0F FF</u>	
			<u>FF</u>		

CRC

Device address	Function code	Number of bytes	Data
			Channel 1 sampling value: 0F FF
			Channel 2 sampling value: 0F FF
			Channel 3 sampling value: 0F FF
			Channel 4 sampling value: 0F FF
			Channel 5 sampling value: 0F FF
			Channel 6 sampling value: 0F FF
			Channel 7 sampling value: 0F FF
			Channel 8 sampling value: 0F FF

### 2. 03 function code

Used to read the holding register, the read is a sixteen-bit integer or an unsigned integer.

For example:

Module address is 01, search module

Host send:	<u>01</u>	<u>03</u>	<u>00 80</u>	<u>00 07</u>	CRC
	Device address	Function code	Register address	40129	Number of registers
Device return:	<u>01</u>	<u>03</u>	<u>10</u>	<u>39 18 20 20 2B 20 06 00 00 01 00 03 00 00</u>	CRC

Device address	Function code	Number of bytes	Data
			Module type: 3918
			Module type suffix: empty
			MODBUS protocol identification: +empty

Module version number: 6.00  
 Module address: 1  
 Module baud rate: 9600bps  
 Parity method: no parity

### 3. 06 Function code

Used to write single save register

For example:

The module address is 01, set the module address to 2

Host      06      00 84      00 01      02      00 02      CRC  
 send: 01

Device	Function	Register	Number of	Number of Data
address	code	address 40133	registers	bytes

Module address: 2

Device return: 01 06      00 84      00 01      CRC

Device address    Function code    Register address 40133    Number of registers

### 4. 16 (0x10) function code

Used to write multiple holding registers.

For example:

The module address is 01, the module address is set to 2 and the baud rate is 9600, no parity.

Host send: 01      10      00 84      00 03      06      00 02 00 03 00 00  
 CRC

Device	Function	Register	Number of	Number	Data
address	code	address 40133	registers	of bytes	

Module address: 2

Baud rate: 9600

Check bit: None

Device return: 01    10    00 84    00 03    CRC  
                   Device    Function    Register    Number of  
                   address    code    address    registers

### 5. Error response

If the address and check bit are correct, but the register address in the command is not within the module address protocol range, the device returns an error command.

No returning for other error conditions

Error command format: device address + error code (0x80 + function code) + exception code (0x02) + CRC

For example:

The module address is 01, the error address is 40138

Host send: 01	<u>10</u>	<u>00 88</u>	<u>00 04</u>	<u>08</u>	<u>00 02 00 03 00</u>	<u>CRC</u>
					<u>00 00 00</u>	

Device address	Function code	Register address 40137	Number of registers	Number of bytes	Data
----------------	---------------	---------------------------	------------------------	--------------------	------

Module address: 2

Baud rate: 9600

Check bit: None

40138 address

Device return: <u>01</u>	<u>90</u>	<u>02</u>	CRC
Device address	Error code	Exception code	

## 2.4 Initial default state

Module address: 1

Baud rate: 9600bps, 8, 1, N (no parity)

Input type: 4~20mA

Display type: engineering unit

## 2.5 Installation method

The analog quantity acquisition module can be easily installed on DIN rails and panels (as shown in the figure below), and they can also be stacked together for user convenience. Signal connection can be done by using plug-in screw terminals, which is easy to install, change and maintain.



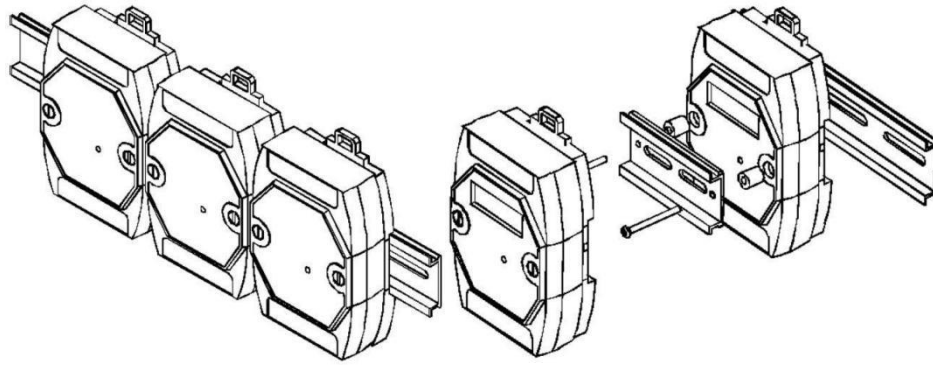

## ■ 3 Software Instructions

### 3.1 Power on and initialization

- 1) Connect the power supply: "+Vs" connects to the positive power supply, and "GND" is grounded. The power supply requirement of the module: +18V— +30V.
- 2) Connect the communication line: DAM-3918 is connected to the computer through the conversion module (RS232 to RS485 or USB to RS485), "DATA+" and "DATA-" are respectively connected to the "DATA+" and "DATA-" terminals of the conversion module.
- 3) Reset: In the case of power off, press the button S1 on the side of the module, and power on until the indicator light stops flashing to complete the reset. Power off and power on again, the module enters the sampling state.
- 4) Calibration: When the module is powered on, open the dedicated calibration software for the module, select the COM number, and fill in the ID of the module. After connecting the module, click to enter the calibration mode. After the calibration is completed, power off and power on the module to let it enter the normal sampling state.

### 3.2 Connect to advanced software

- 1) After connecting the module, power on, open the DAM-3000M advanced software, click the connected COM, the following interface will appear, select the baud rate 9600, and the other options are the default, click the search button.

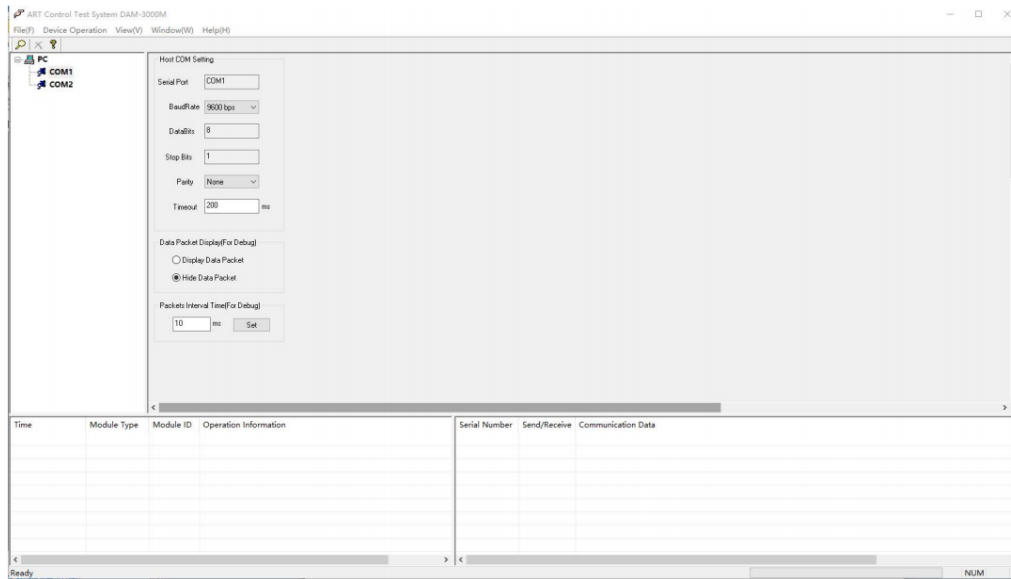

2) If the following configuration interface appears, it is normal. If the module information does not appear, repeat the above steps.

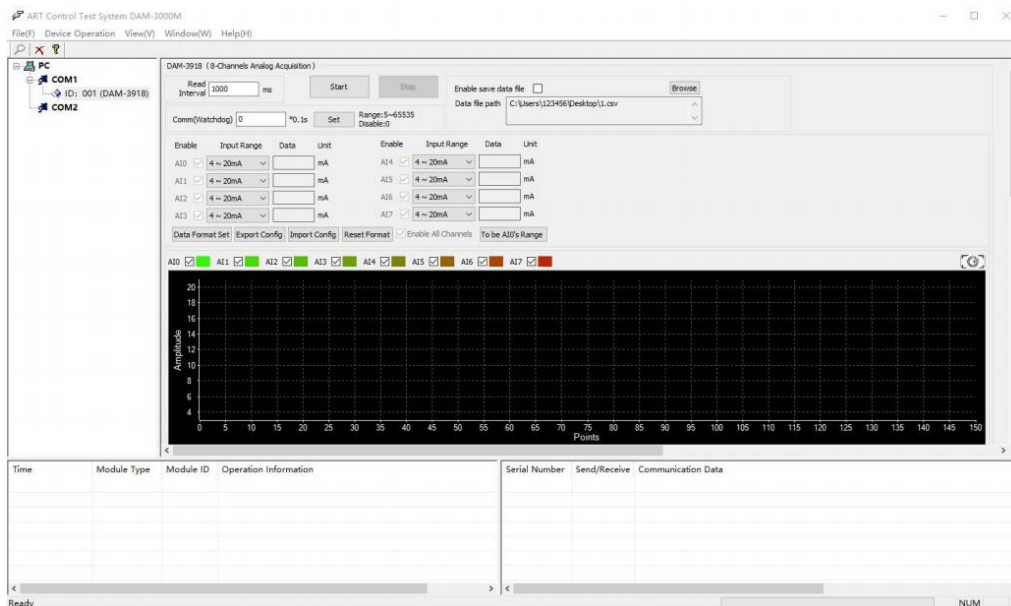

3) Click the module information to display the configuration information interface, click the drop-down arrow of range selection to display the range type, select the input type to complete the configuration, and the 8 channels of the module can be configured separately.

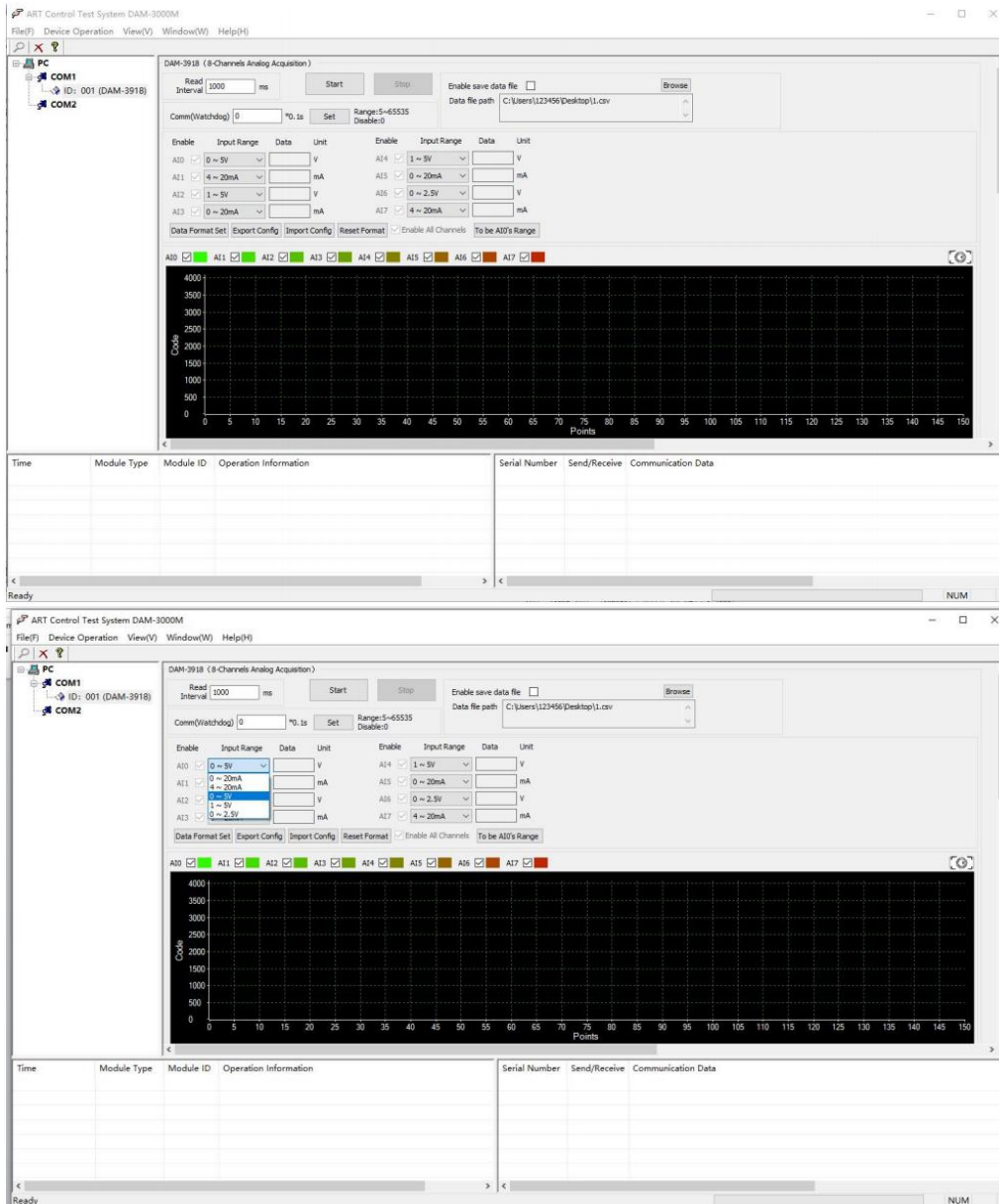

4) If you need to modify the module information, double-click the module address information on the left, and the following interface will appear, you can change the module's baud rate, address and parity method. After the modification is completed, you need to click the restart button, and then reconnect the module.

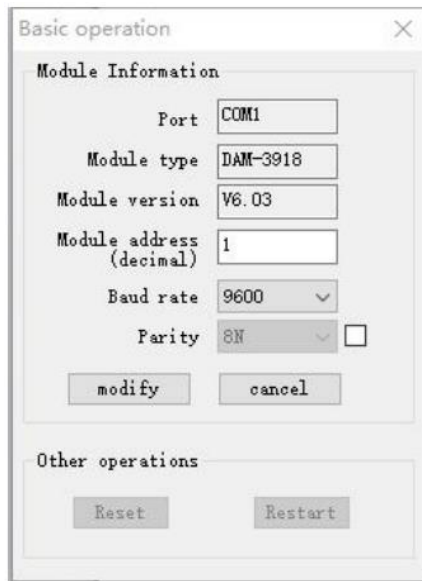

5) After the module search is successful, the module reset is completed. Repeat the above steps 3-5 to sample normally.

6) The data display format is divided into three types: "engineering unit", "original code value", and "customize". In engineering unit, the voltage value or current value is displayed, and the original code value displays 0~0xFF hexadecimal data. For convenient use, customization allows customers to directly convert the original code value to the desired field value. The premise of using customization is that: 1)customer's field data and the module acquisition range are linear; 2)customers need to provide the minimum and maximum value of the corresponding ranges. If an error is provided, the converted value will be also wrong. The display interface is shown in the figure below.

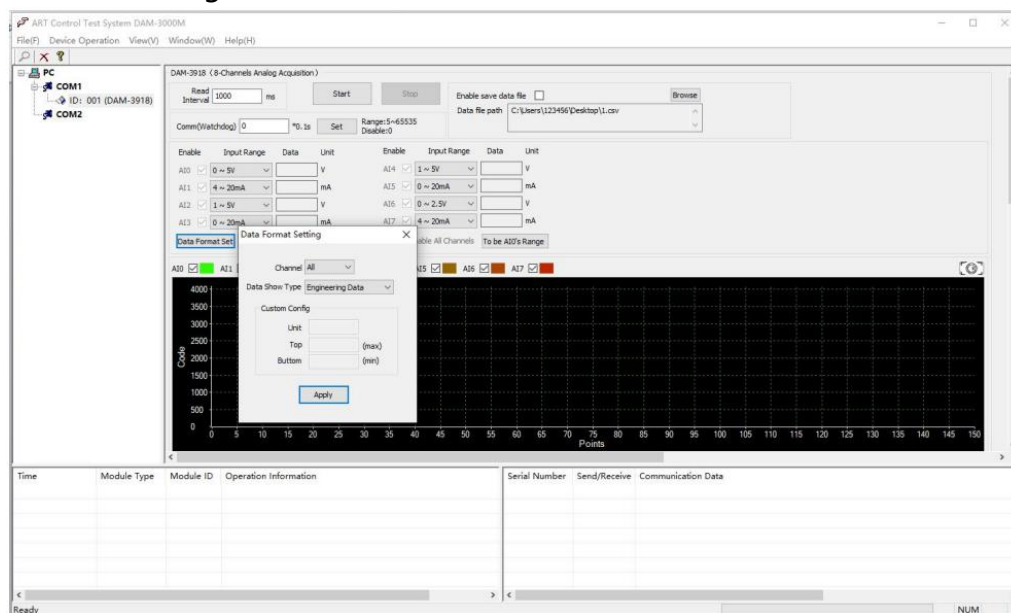

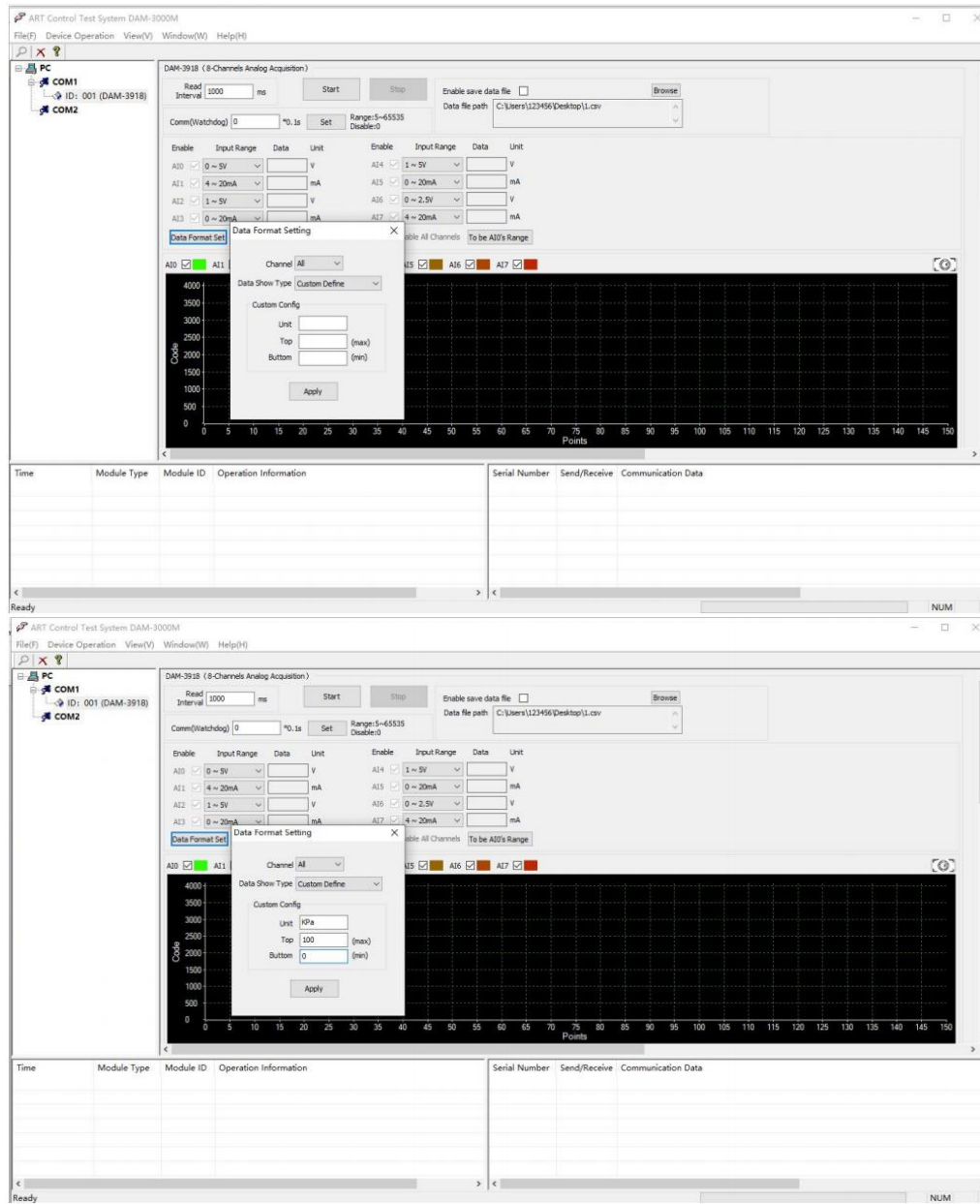

7) The software has a graphical display function. The acquisition status of each channel can be graphically viewed, as shown in the following figure:

